



## Circuit Protection

Circuit protection is a generic name for fuses and circuit breakers. These devices are used to keep an unlikely event from precipitating an unhappy disaster. Fuses and circuit breakers are included in an electrical system to accomplish one thing: keep the wiring from creating a fire hazard in the event that the wire becomes overloaded.

### FUSES VERSUS CIRCUIT BREAKERS, WHAT'S THE DIFFERENCE?

Fuses predate circuit breakers by many years. I have lived in houses built in the early days of electrical distribution that used a device called a "plug fuse" that really didn't plug but rather screwed into a threaded socket identical to the ones used to hold household light bulbs. I can also recall the infamous penny fix wherein a blown fuse was temporarily bypassed by placing a copper penny in the bottom of the fuse socket and then screwing the blown fuse back into the hole thus returning the lights to the ON state. It also placed the whole house at risk! It seems that fuses and toilet paper share a common attribute: few people remember to buy more when the last spare has been installed!

The simple appearance of a fuse can be misleading. The physics of designing and fabricating reliable fuses is not a trivial task. The fuse operates as an electrical equivalent of weak link in a chain. Its current sensor element is a conductor of carefully chosen alloy whose resistance and thermal characteristics provide predictable meltdown and interruption of the faulted circuit.

Fuses are sold primarily by their current rating, yet I can show you a 1 amp fuse the size of a match head and another the size of a small rolling pin. A second and very important requirement of fuses (and breakers) that is not so immediately obvious. They have fault current and maximum voltage ratings as well. A fuse may also need special thermal characteristics to make it either tolerant of or perhaps especially sensitive to short overload

conditions. If a fault current rating were not important, then a 2-amp fuse used in the protection of an aircraft branch circuit at 14 volts could also be used to protect a branch from a 440 volt AC power system in a building. The difference in these two situations is the worst case current that can flow when a short does occur downstream of the fuse.

For example, in your aircraft system, if you were to deliberately short the end of one of your circuit breaker branches to ground, the absolute maximum current that could be expected to flow in the microseconds before the fuse opens is on the order of 200 to 400 amps! Seems like a lot and the fuse thinks so too. That is why it opens up so quickly with the little flash of fire and the smoking up of the glass tube which contains it. Consider the same fuse in an application to protect a branch from a 440 volt bus in a building. Now the fault current potential rises to as much as 10,000 amps. Again this is only for microseconds but how much energy can be pumped into the little flash of fire that you observed in the 14-volt circuit? The answer is much, much, more. So much in fact that the fire would never go out. The fuse wires would simply melt away inside the glass tube and be replaced by a fire that would continue to destruction of the fuse holder and probably the downstream wiring or equipment that the fuse was supposed to protect. That is why you can find 2-amp fuses that range in size from size of paper match head up to an inch or in diameter and 6 inches long. Both will open at the same current but they are designed to work in very different environments.

The same considerations must be made in the design of circuit breakers. Now, how does this affect your decisions? Not much. The fault currents to be expected in a 14 or 28 volt DC vehicular system are well within the capabilities of just about any fuse or circuit breaker. The confusion factor to be aware of is the voltage rating that often appears on fuses and circuit breakers. A gentleman at Oshkosh '88 asked, "where he could find breakers rated

for 14 volts? All that he could find in the Fly-Market were marked for 32 volts!" I was somewhat startled by the question because I had never considered the implications of such a marking. But it was a good question and it will be answered again on these pages. . . Be advised that such markings on fuses and circuit breakers are maximum voltage ratings not operating voltage ratings. Furthermore, the voltage "rating" on a fuse or breaker is in reality a broad sort of fault current rating. Breakers and fuses may be considered for use as long as the voltage rating on the device is equal to or greater than the system voltage of your airplane.

#### ACRES OF BREAKERS . . .

A look at the power distribution panel of a modern twin turbo-prop will give the observer a look at what it's like to protect every wire in a complex airplane. When I was working on the Piaggio P-180 project a few years ago (it was the Gates-Piaggio GP-180 then), we had something on the order of 140 circuit breakers in the airplane; about 70 per side! And that was just in the cockpit, a few dozen more were stashed back in the tail. In that instance, virtually every wire which left the power distribution bus was protected with a circuit breaker. We sized the power distribution panels by the square foot!

I've been asked numerous times about how much is needed in the way of circuit protection; especially by the single place and tandem cockpit airplane builders where panel space is really at a premium. But even if your airplane is a two-place, side-by-side design, there is no point in carrying around any more weight nor using up any more panel space than is absolutely necessary. One is loath to assign panel space to components that are seldom called upon to protect the electrical system from an overload fault.

#### ONE FOR ALL OR ALL FOR ONE?

Question: "Does one really need a separate fuse or circuit breaker for each branch circuit from the power distribution bus?" Let us consider some additional space saving factors. There is no compromise of safety by powering more than one device from the same breaker as long as the breaker rating versus wire size are not exceeded. Example: Suppose you had three lighting circuits, none of which draws over one amp. The smallest wire to be used in any circuit is 22 AWG which is normally protected at 5 amps. Let us further suppose that the loss of all three lighting devices poses no real threat to your safety or mental well being. I would suggest then that these

devices might share the same 5 amp fuse or breaker. Given that the fuses are so much less expensive per protected circuit than breakers, a builder is less inclined to cut corners by doubling up loads on a single fuse. Each powered circuit can enjoy its own circuit protection. Another plus for multi-slot fuseblocks is their compact size, it's no big deal for dollars, weight or space to plenty of SPARE slots for future addition of powered equipment.

#### IN-FLIGHT RESETABILITY, REAL SECURITY OR SECURITY BLANKET?

What is the value of locating the a fuse or breaker within convenient reach of the pilot? One might expect, and it is obvious that most failures are passive in nature. That is to say that the failure of any one widget usually results only in the loss of that one device's ability to do its job. Fuses and breakers prevent failure from propagating to other systems by way of power losses or incineration. When the failure manifests itself by opening the breaker or fuse likelihood of recovering the system by replacing a fuse or pushing in a breaker is very, very small. So. . . . Consider putting these critters in less handy places. How about a fuse panel that faces down, behind the panel, in the leg wells of the Eze-type airplanes. Or perhaps they could be on the forward face of the pilot's seat support, under the pilots legs.

The most likely cause of a breaker popping is from some failure within a device, be it a radio, light fixture, landing gear motor, etc., which has caused that device to draw an unusually high and ultimately dangerous amount of current. What's value is there in being able to see that a breaker has popped? Suppose you turned on your transponder and the breaker powering it pops. What do you know? The transponder is broke. What is the likelihood of recovering the use of that transponder by pushing a breaker back in? Whatever caused the breaker to pop in the first place is probably still lurking in there waiting to pop it again! Suppose you turn the transponder on and it doesn't work and the breaker does NOT pop. Now what do you know? The transponder is still broke. The second later failure mode is 100 times more likely than the first failure mode. Further, being able to see that a breaker feeding the transponder is or is not popped conveys no useful information to the pilot to help him with his task nor does the popped/not-popped information change the probable outcome of the flight.

The next most probable reason for fuses to open are wires whose integrity has been compromised. Perhaps an end has come loose and is laying on the sheet metal

somewhere or the insulation has rubbed through at some point where the wire was improperly installed. In a plastic airplane the probability of this event is small to zero! There is no metallic airframe to ground on. Every device in the plastic airplane must be supplied with a "ground" by means of a separate wire: usually the same kind of wire that carries the main power supply. Both wires are insulated. Here we have an equivalent of the double insulation found in some power tools. These devices usually have plastic housings and do not require three wire power cords to be approved for safety considerations.

I have a lot of builders cite the FARs with respect to use of fuses in their airplanes. They mistakenly believe there is some requirement to have so many spares on hand for in-flight maintenance. Check out the FAR 23.1357 for yourself. It says a number of good things about how to utilize circuit protection in an airplane but let's look specifically at:

***(d) If the ability to reset a circuit breaker or replace a fuse is essential to safety in flight, that circuit breaker or fuse must be so located and identified that it can be readily reset or replaced in flight.***

***(e) For fuses identified as replaceable in flight--***

***(1) There must be one spare of each rating or 50 percent spare fuses of each rating, whichever is greater; and***

***(2) The spare fuse(s) must be readily accessible to any required pilot.***

Note that it speaks specifically of fuses powering equipment essential to safety in flight. Repeat after me, "I will have no item of electrically powered equipment upon which my comfortable termination of flight depends." See chapter 17 for more information on this. Further, while FAR23 may be consulted for good advice and accepted practices, it has no regulatory bearing on your project whatsoever.

#### FUSES OR BREAKERS

Question: "Is the weight, volume and cost of a breaker justified when a fuse will do the same basic job?" In most instances, a breaker and fuse can be considered to be electrically equivalent; either device will provide the prescribed safety margin with respect to electrical fires.

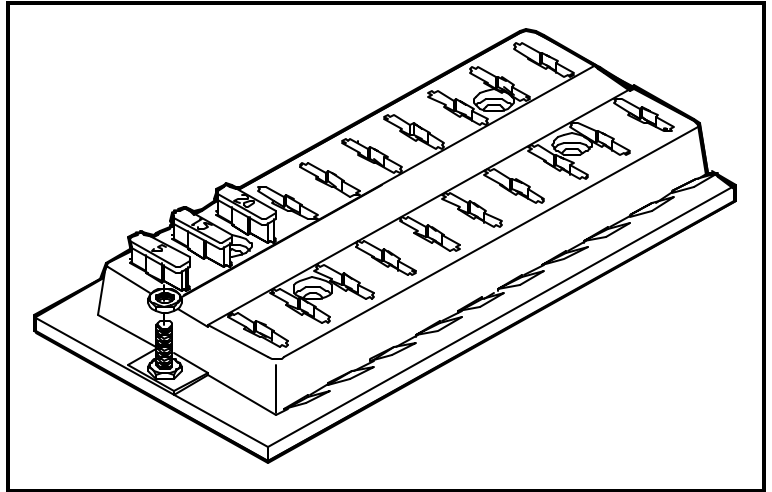

Figure 10-1. Multi-Slot Plastic Fuseblock.

In the ten years I've been evolving this work, I've come to the conclusion that fuse blocks for the plastic, plug in fuses are equal to circuit breakers for safety and a whole lot less expensive than breakers. The best thing about these devices is ease of installation. In a matter of minutes, with the installation of a single component, you replace up to 20 breakers along with the work it takes to fabricate of bus bars and breaker panels. Fuse block are all 3.5" wide. We stock a 6-slot device that's 2.5" long, a 10-slot device with a length of 4", and a 20-slot block that's 7" long. All are about 1.3" thick. They utilize my favorite wire termination system, the 0.25" wide fast-on tabs for each fuse location. I encourage builders to mount these products with GROUND maintenance accessibility in mind. If that means you can't reach them in flight no problem.

The fuse block's grip on the tabs of a plastic fuse is much superior electrically than the u-shaped clip found on older cars with the 1/4 x 1-1/4" glass fuses. I'm comfortable with using the plastic fuseblocks with feeders up to an including 15 amps.

#### SWITCH-BREAKERS

There are breakers that have toggles on the front which are intended to be used as combination switch and circuit breaker. The major problem with most of the breakers of this type is that they force you to build a second bus bar distribution system on left side of the aircraft where pilot operated controls are grouped. The fuse block approach to distribution from the bus bar has a bus bar already fabricated and almost totally enclosed inside the fuse block.

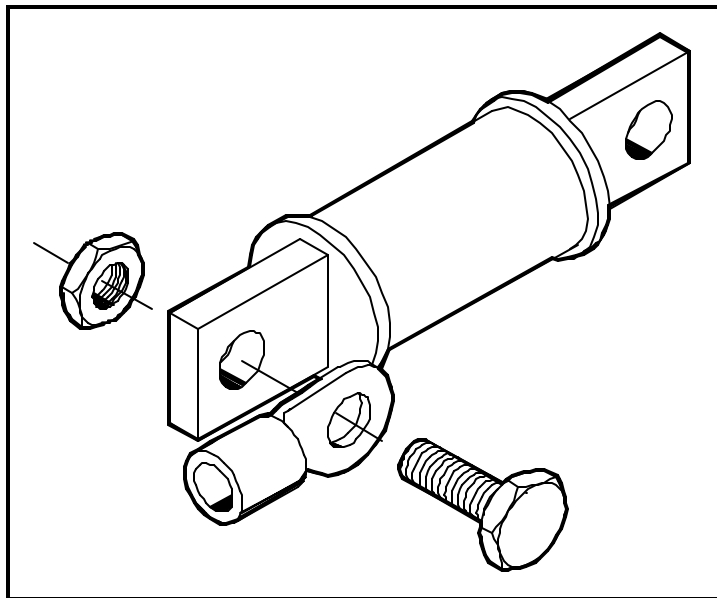

Figure 10-2. In-Line Fuse Adaptation of the JJN/JJS Series Cartridge Fuses.

Many builders view the switch-breaker as a time and space saving option. In the final analysis, there is no faster, less expensive nor more compact wiring combination than the switch/fuse-block combinations illustrated throughout this book.

#### FAT FUSES

An interesting fuse product not generally found on airplanes but non-the-less quite useful is the cartridge fuse with flat tabs suitable for bolting to a terminal on a wire. I've been using these fuses to protect the alternator output or B-lead feed so that the alternator can be conveniently tied into the starter contactor on the firewall. This technique is shown in all of the power distribution diagrams in this book.

Reliable fuses for over large loads, 50 amps or more can be had. In fact, good fuses up into the hundreds of amps in size are readily available. These are tab mounted devices which are held electrically and mechanically by retaining nuts on threaded studs. They are used extensively in the heavier twins and are usually referred to as "current limiters". Single engine airplanes generally don't have protection requirements that large. We offer 80-150 amp B-lead fuse kits from our website catalog with the vast majority of the installations taking an 80A fuse.

Our B-lead kit contains a fuse, terminals, assembly

hardware and pieces of heatshrink for covering terminals. A larger hunk of heatshrink is provided to cover the entire assembly after it's all bolted together. This is a low cost, light weight technique for protecting the alternator B-lead and keeping all the noisy fat wires out of the cockpit. You can find similar fuses at distributors forelectricalcontractors. Ask for the Bussmann JJS or JJN series fuses or their equivalent.

In the power distribution diagrams further back, you'll find only a few circuit breakers called out. I recommend crowbar overvoltage protection which needs a circuit breaker. I'll generally install the ALT FIELD breaker in the same row and adjacent to the DC PWR MASTER switch.

#### THE "OTHER" FUSE - FUSIBLE LINKS

A third fusible protection device is called a "fusible link". Used in automobiles for decades, I've found several places where they make sense on airplanes as well. The fusible link is simply a piece of wire, 4AWG wire steps smaller than the wire it is supposed to protect. 4AWG wires steps is a 60% reduction in cross section. Obviously, this becomes the requisite "weak link" in a power pathway. For a fuse to do it's job, it should fail in a predictable manner that does not create a hazard to the airplane or its wiring. To insure this orderly destruction of the fusible link wire, we'll cover it with a Fiberglas sleeving impregnated with silicone rubber.

One fabricates the fusible link by butt-splicing a 4" piece of 4AWG smaller wire to the hot end of a protected feeder and terminating it with the proper terminal to mate up with the feedpoint hardware. Our website has a photo pictorial on how this is done. A fusible link takes place of an inline fuse holder. Since it's made from ordinary wire, terminals and butt-splices, the long term integrity of the device is quite good. You'll see fusible links called out in numerous places in the power distribution diagrams at the back of the book.

As a general rule, I wouldn't recommend a fusible link for anything except relatively low current feeders such as alternate feed to the essential bus, always hot feed to an electronic ignition, Hobbs meter, electric clock, etc. A 24AWG fuse link should be used to protect a 20AWG wire but the circuit load should be limited to 3A maximum (24AWG wire rating). A 22AWG wire protects an 18AWG wire in a 5A maximum (22AWG wire rating) circuit. There are a few places where some larger links are shown in the

power distribution diagrams for protecting the feed lines of PM alternators. Our website catalog offers a Fusible Link Kit with sufficient 24AWG wire, silicone impregnated Fiberglas sleeving and butt-splices to fabricate 4 fusible links.

SO, YOU'RE GONNA DO THE  
BREAKER THING ANYHOW . . .

If you really, REALLY gotta have breakers, then consider the following: Bus bars are best made from sheet brass or copper . . . it doesn't need to be real thick. .032" is fine but it can be thicker. Hobby shops and many hardware stores have a display of metal shapes by K&S Engineering. Their display has various compartments of aluminum and brass shapes including a 4 x 10" sheet of 0.032" brass. Their catalog # is K&S253 and costs about \$4.

Go to a sheet metal shop and cut some 1/2" wide strips off the long side. Two or three are enough to do the whole breaker panel in most airplanes. The best breakers for this task have screw terminals as opposed to fast-on tabs or solder terminals. Measure the thickness of the breaker you plan to use and decide how far apart you'll space your breakers on the panel. . . . I use 0.70" spacing for the miniature Klixon breakers. Drill a row of #26 holes in your strips of brass, 0.70" apart. Mount the breakers on 0.7" centers and use the strips of drilled brass to bus all of the breakers together. Obviously, you'll need separate bus bars for the main and essential busses.

If you must arrange the breakers in multiple, shorter rows, then you'll need inter-bus jumpers to tie common rows together. This is easily done with 10AWG wire bolted to the bus bars in the spaces between breakers. Don't use breaker screws for this. Inter-bus jumpers should have their own 8-32 screws, nuts and lockwashers. If you need a multiple row installation, put all the high current breakers (like landing lights, taxi lights, pitot heat, hydraulic pumps, etc) on one row. Then attach the main bus feedline to this bus bar with its own 8-32 screw, nut and lockwasher. All remaining breakers won't exceed 30 amps continuous loading so the 10AWG inter-bus jumper is not going to be stressed too hard.

If you really, REALLY want to use switch-breakers then plan on two breaker panels. One on the left side to handle the switched circuits and one on the right for the remaining, non-switching breakers. They'll both need the brass strips to tie the one side of each row together. Generally, all high current loads (except perhaps a hydraulic pump) are pilot switched, so bring the main bus feed into the pilot side breaker panel. Then fabricate a 6AWG jumper to take power to the right side. Take some pains to secure this wire from potential chafing and other sources of mechanical compromise. Again, don't use breaker screws to attach main power feedlines or inter-bus jumpers . . . these things should get their own 8-32 fasteners.