



AeroElectric Connection
6936 Bainbridge Road
Wichita, KS 67226-1008
Phone/Fax: 316-685-8617
Email: nuckolls@aeroelectric.com
Website: www.aeroelectric.com

Installation / Operation Instructions
Microair Avionics
760 Channel VHF Aviation Transceiver



The 760 VHF Transceiver is manufactured by:

Microair Avionics Pty. Ltd;
Airport Drive (Postal Box 5532)
Bundaberg West, 4670
Queensland
Australia

Phone: (61)741553048 Fax: (61)741553049
Email Sales: sales@microair.com.au
Email Support: support@microair.com.au

Synopsis of Warranty
from
Microair Literature Provided with their products:

Microair Avionics Pty. Ltd. will warrant that this product is free of defects in material and workmanship for a period of one year under normal use. Microair's obligation under this warranty is limited to repair or exchange of the product or any defective part of the product if the product or part is returned to us shipping prepaid.

Microair cannot accept liability for service charges for removal, reinstallation and adjustment which are the responsibility of the buyer and are not covered by this warranty. Consequential damages and freight costs are also not covered by this warranty.

Microair will not accept responsibility for damage due to misuse, accident, or neglect. The warranty will be void if the product is modified in any way which in the opinion of Microair Avionics Pty, Ltd. affects the performance of the product.

Warranty repairs do not extend the original warranty, the warranty is limited to one year from the date of purchase.

Microair 760 is a registered trademark of Microair Avionics Pty. Ltd. (ACN 091040032).

This synopsis was developed from Microair literature in print at the time this manual was developed. Refer to official Microair papers supplied with your radio for any significant variation from what we've excerpted herein.

Service letters and other update information can be found on Microair's website at www.microair.com.au

1.0 MICROAIR 760 VHF TRANSCEIVER SPECIFICATIONS	
Type	Amplitude Modulated (AM) Aircraft Transceiver.
Channels	760 channels, 25 kHz spacing, 118–136.975 MHz
Frequency stability	0.002% over temperature -20 to +60 degrees C
Frequency Display	2 line alpha numeric LCD display (backlit)
Frequency control	PLL frequency synthesis, Microprocessor controlled.
Memories	25 pilot programmable channels. Channel 25 is one-touch priority channel. Frequency data stored in non-volatile EPROM.
Operating Voltage	10.3 to 16.0 VDC
Power consumption	Receive (no signal) 86 mA Transmit 1.2 Amps Backlight 40 mA
Power output	4 Watts carrier, 12 Watts PEP
Receiver sensitivity	A 1.0 uV signal modulated at 30% with 1 KHz audio produces 12 dB of quieting (12 dB sinad test).
Receiver selectivity	-70dB
Squelch Threshold	.6uv to 5.0 uV
Speaker Volume output	Nominal 5 Watts (4 ohms)
Headset Volume output	Nominal 100 Mw into 600 Ohms
Dimensions	2.6" W x 2.3" H x 5.3" D (Includes Connector)
Weight	14 ounces
Qualification	DO-160D xxxxxxxxxxxxxxxxxxxxxxxxx

2.0 INSTALLATION

2.1 Parts supplied

- a. Microair VHF 760transceiver.
- b. Microair Factory Supplied manual.
- c. AeroElectric Connection pre-wired installation harness.

2.2 Parts not supplied

- a. Headset and microphone jacks for up to two crew stations
- b. Remote frequency flip-flop push button(s).

- c. Interphone select switches (either individual crew PUSH FOR ICOM buttons or a single pole switch to activate the hot-microphone intercom function).
- d. 2A Fuse or circuit breaker that supplies power from the selected aircraft bus.
- e. VHF Comm antenna
- f. Antenna feedline (RG-400 or RG-142 recommended)
- g. BNC cable male connector to mate antenna feedline to radio
- h. Wheel or stick mounted PUSH TO TALK buttons for transmit and intercom functions.
- i. Audio system as needed to mix audio from other receivers, warning tones and audio from the 760 VHF transceiver.

2.3 Transceiver Installation

Survey the proposed mounting location for clearance to side and rear. Allow for rear cabling and connectors. Cut holes in panel in accordance with the adjacent figure.

Install the transceiver using screws supplied.

Connect pre-wired installation cable to the mating connector on the rear of the radio.

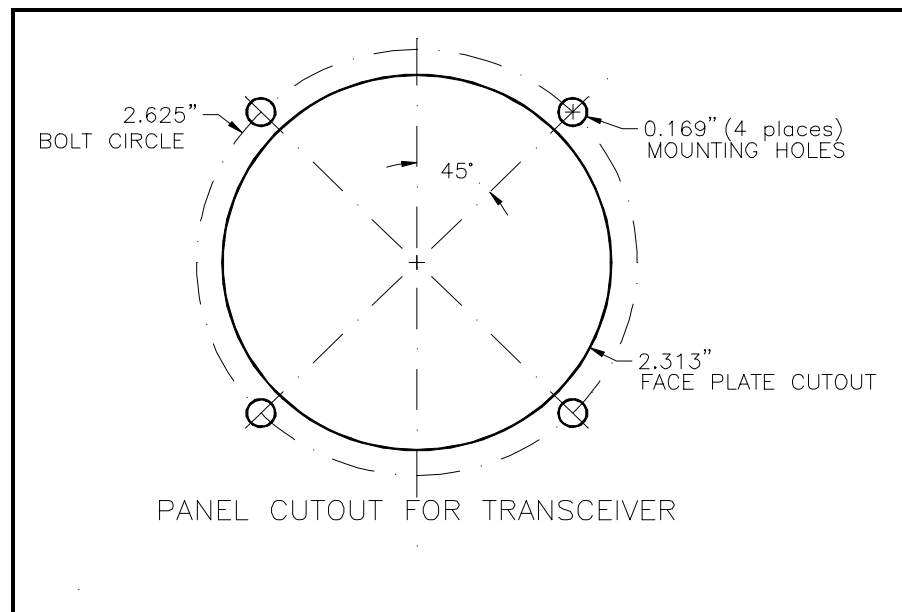

2.4 Headset and Microphone Jacks

Headset and microphone jacks should be located convenient to the user. If possible, position the jacks so that headset cords route out of busy cabin space. For example, in a high wing airplane, consider mounting jacks above, behind and outboard of the user's seat. This location would reduce cord-clutter in the cockpit.

Headset and microphone jacks should be insulated from airframe ground. In metal airplanes, this calls for the use of insulated washers around the threaded bushing of each jack to prevent electrical connection to the airframe via the mount. You can also consider building the jack support panel from a

thin sheet of fiberglass or phenolic. Insulated mounts prevent conduction of electrical system noise into the radio's audio by way of a "ground loop".

2.5 Press to Transmit and Press to Intercom

Momentary push buttons can be mounted on control stick grips for convenient access by the user.

2.6 Power, Signal and Control Connector

The following table describes functionality of each pin in the transceiver's 15-pin, D-subminiature interface connector. The table also describes the AeroElectric Connection harness wire color and size for each pin.

760VHF Pinout List (Colors and wire sizes refer to those supplied in the AeroElectric Connection fabricated installation harness).	
Pin #	Signal Function and Wire Color/Size
1	Pilot Mic Hi (Shielded Trio - Yellow)
2	Audio Lo (Shield ground for both headset and microphone wires)
3	Copilot Mic Hi (Shielded Trio - Red)
4	Not Used
5	Intercom Enable (White 22AWG)
6	Not Used
7	Push to Transmit (Shielded Trio - Blue)
8	Backlighting (Blue 22AWG)
9	+Ship's Power 10-15 Volts DC from 2A fuse or circuit breaker. (Yellow 20AWG)
10	
11	-Ship's Power Ground - Instrument panel ground bus (Black 20AWG)
12	
13	Memory Flip-Flop (Violet 22AWG)
14	Headset Audio Hi (Shielded White)
15	Speaker Audio Hi (Green 22AWG)

2.7 Harness Connections: The harness is fabricated with wires that are at least 10-feet in length. Begin by installing the connector on the back of the transceiver and routing the wires toward their respective destinations working away from the radio. Be sure to allow 4-6 inches of slack in the harness immediately behind the radio for a "service loop". Connect harness wires into the ship's system as follows:

a. Power: Connect the positive ship's DC power wire (20AWG Yellow) to a 2A fuse or circuit breaker designated as power source for this radio.

b. Ground: Connect the ship's DC power ground wire (20AWG Black) to the instrument panel ground bus.

c. Microphones: Route the microphone (shielded trio) wires from the transceiver to the pilot's jacks. Solder wires to the microphone jack terminals as described in the adjacent illustration and in the wiring diagrams at the back of this document. In a two place airplane, extra wire provided will carry microphone signals from the pilot's mike jack to the copilot's jack. The sleeve and tip terminals of the pilot's mike jack will have two wires

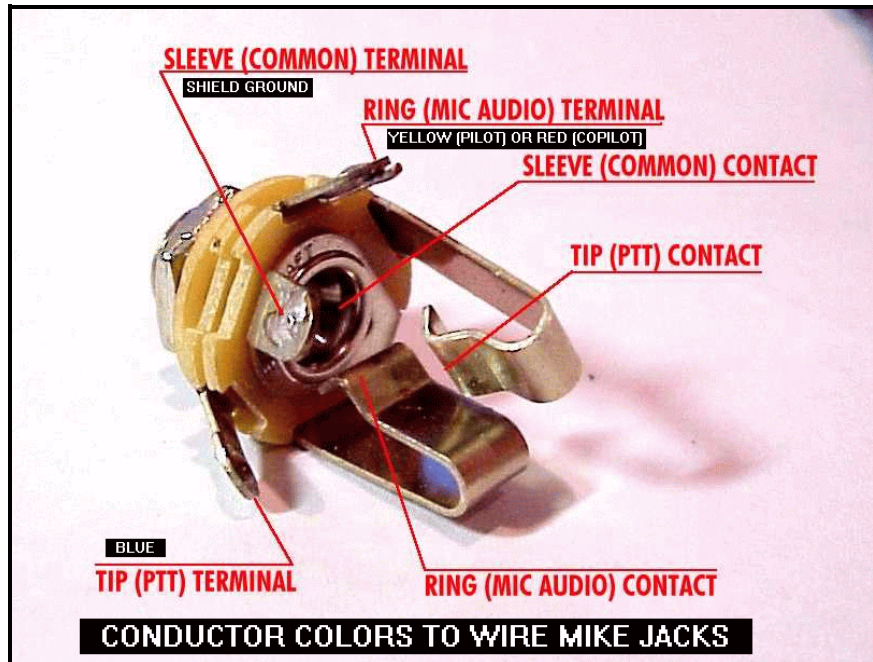

each. Plan ahead and have both wires soldered in place before you put heat shrink over the finished joints. It's okay to have plenty of "unshielded" wire at each microphone jack . . . 2 to 3 inch pigtailed hanging out from under the shield will facilitate wiring and will not adversely affect performance.

Both mike jacks get shields tied to the sleeve (common terminals) and blue wires tied to the tip (push to talk) terminals. The pilot's mike jack gets a yellow wire tied to the ring (mic audio hi) terminal. The red wires splice together at the pilot's mike jack and carry on to the copilot's jack where the red wire ties to the ring (mic audio hi) terminal.

d. Headsets: Route the headphones audio wire (shielded single) from the transceiver to the pilot's headset jack location. Shield of the headset wire connects to the jack's sleeve terminal. The white (center conductor) wire ties to the tip terminal. Again, in a two place airplane, the pilot's microphone jack gets a pair of wires on each terminal when extra headphone wire is daisy-chained over to the copilot's headset jack.

e. Push to Talk - Transmit: Install optional press to talk switch(es) and wire to the microphone jacks with 22AWG twisted pair wires as shown in page 2.1 of the wiring diagrams. PTT switch(es) must be momentary-ON push buttons.

f. Memory Flip-Flop: Install optional remote memory flip/flop switch(es) and wire to the VIOLET 22AWG wire wire as shown in page 2.2 of the wiring diagrams. Remote frequency flip/flop switch(es) must be momentary-ON push buttons or toggle switches.

g. Push to Talk - Intercom: If intercom capability is desired, install optional remote Push to Talk - Intercom switch(es) and wire to the WHITE 22AWG wire wire as shown in page 2.1 of the wiring diagrams. Push to Talk - Intercom switch(es) must be momentary-ON push buttons or toggle switches.

h. Cabin Speaker: If optional cabin speaker is installed. Route GREEN 22AWG wire to speaker location and solder to one of the speaker's terminals. Ground the other speaker terminal to instrument panel ground bus. It may be desirable to include a SPEAKER On/ Off switch in this circuit. NOTE: Speaker use is not recommended in high noise aircraft.

i. Back Lighting: Connect the backlighting circuit for continuous illumination as shown on page 2.1 of wiring diagrams. Optionally, you might wish to install a backlighting control switch as shown on page 2.2. Backlighting is energized by application of aircraft power to the BLUE 22AWG wire. Backlighting is provided by light emitting diodes with VERY long life. Continuous backlighting presents no potential for a service life problem.

Note that all external switches except backlighting connect their respective signal lines to ground. Any unused wires in the harness should be cut off approximately 6" behind the radio, capped with small piece of tape and tied into the wire bundle. The short pig-tail gives you the option of using the wire a some later time by means of a butt-splice.

Audio System

It's beyond the scope of this document to anticipate the audio system requirements for every installation. In many installations, the 760VHF is the only receiver. In this case, audio wiring shown on the first two pages of the diagrams will suffice. If you have more than one receiver -OR- if you plan to have a stereo entertainment and/or need to route electronic warning tones to the headsets, then a system like that illustrated on the last two pages of the wiring diagrams is suggested. Information presented on the last two pages are not a part of this installation and are provided as a suggestion for expanded audio system capabilities.

2.8 Antenna Installation and Tuning

Install VHF Comm antenna in accordance with the manufacturer's instructions for the antenna. If you are fabricating an antenna, trimming of antenna for best performance at 122 MHz is desirable. Use of a variable frequency antenna analyzer (Note 1) is recommended. After installation, check the antenna over the range of 118 to 137 Mhz. A VSWR of less than 3:1 over the entire range is acceptable. SWR readings higher than this degrade performance and can cause damage.

3.0 On-Air Testing

Before transmitting check all connections and switch on. Operate controls as per section 6. A simple on air test for audio quality on transmit and receive should be done.

Have someone monitor your signal on another radio. Better yet, have someone talk to you on your newly installed radio while you listen on a remotely located transceiver such as a hand-held transceiver or another aircraft.

Some radios may become overloaded by very strong signals due to inadequate separation. While not dangerous to the radios, received signals may be poor quality when in fact, there is nothing wrong with either radio. If initial tests suggest poor audio quality, conduct the test with at least 100 yards between your airplane and the remote transceiver.

Press the transmit button and speak into the microphone at normal voice level. Most installations produce adequate transmit audio modulation levels with the factory settings for microphone gain. However, for the best performance of your transmitter, you can have an avionics shop check your transmitter's output using an on-air modulation monitor.

Transmit a test call on the other radio and monitor the audio quality. With the volume control up 3/4 the audio should be loud and not distorted.

Set the squelch and have the station transmit, the squelch should break crisply and without delay.

4.0 OPERATION OF EQUIPMENT

4.1 Description of Controls:

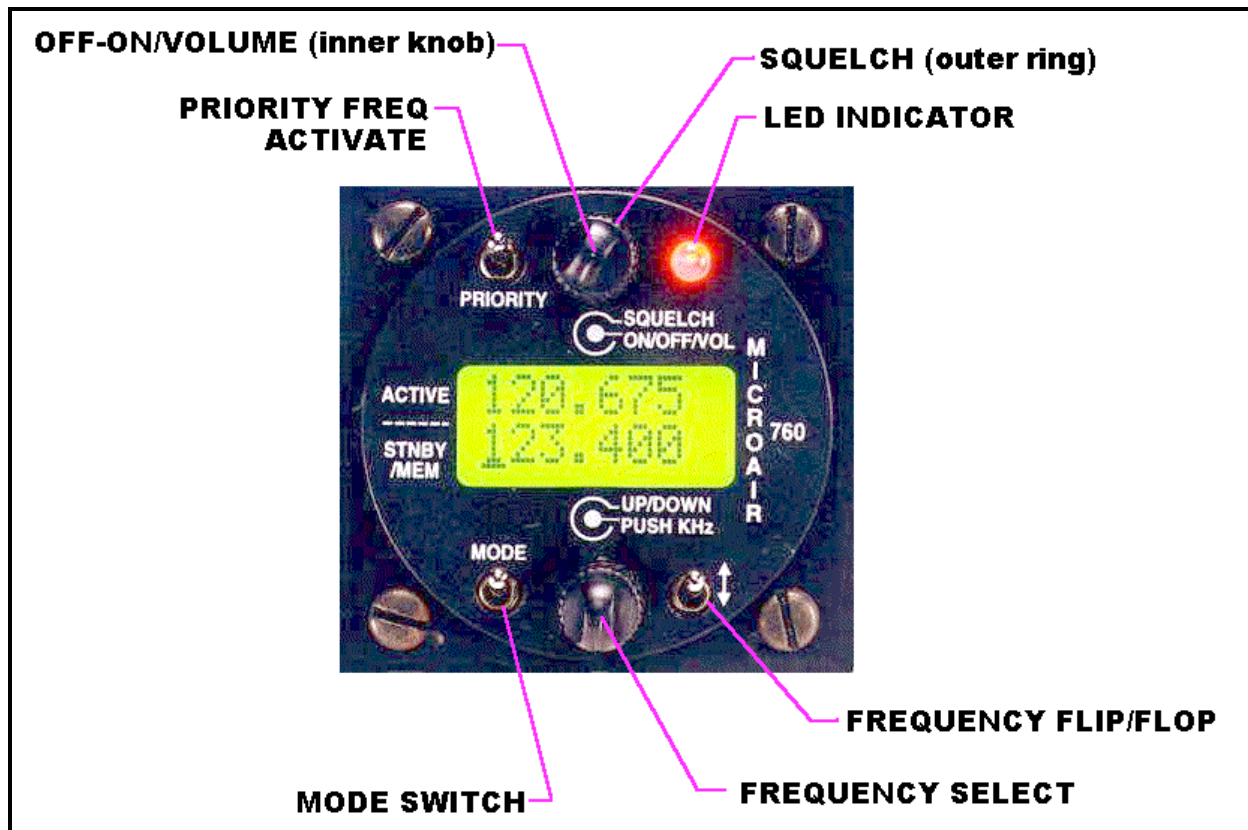

OFF-ON/VOLUME Control: Turn fully anti-clockwise to switch off. Turn clockwise to switch on and adjust volume up.

SQUELCH Control: The outer ring control adjusts the mute threshold. Clockwise for closed.

PRIORITY SWITCH: Activating this control will switch to memory location 25. It also doubles as memory channel delete.

LED INDICATOR:

- a. A clear display indicates a muted receive condition.
- b. Steady green indicates Squelch open or a signal present.
- c. Steady red indicates a transmit condition.
- d. Flashing red indicates that the PIT has been on for longer than 40 seconds. (This is helpful for indicating a possible jammed PIT switch, which can interfere with others and flatten your battery).

MODE SWITCH: selects 3 display pages.

- a. Default is 2-line frequency display. The top line is the active frequency. Bottom line is the change or Stnby (standby) frequency. Turning the knob left or right will change the Mhz (121, 122, 123 etc) Press the **FREQUENCY SLECT** knob once to activate the kHz change (025,050,075 etc) the cursor will underline the KHz, (after 5 seconds of inactivity it will revert to Mhz). To transfer the standby frequency to the active simply hit the **FREQUENCY FLIP/FLOP** switch once. The active and standby frequencies will trade places. The top line of the display is the active frequency.
- b. Push **MODE** again to access the memory display - there are 25 memory channels that can be displayed. Turn the knob left or right to move the channels up or down. To scan hit the arrow key. To stop scanning hit the arrows or activate the PIT. Note: if the memory channel is empty it will not be displayed.
- c. Push in the **MODE** again to display the memory-programming page.

MEMORY TOGGLE: In the active/stnby mode it acts as a flip flop switch, in memory screen it toggles up by one or hold down for 3 seconds and it will enter scan.

4.2 Memory programming

- a. Press the **MODE** switch until PROG appears.
- b. Use the **FREQUENCY SELECT** knob on the bottom of the radio to change the MHz to the desired frequency.
- c. Press the **FREQUENCY SELECT** knob in once and note that the cursor has jumped to underscore the kHz digits and rotate the knob to select the desired frequency. Note if you do not change this within 5 second the cursor will change back to the MHz position.
- d. Press the **FREQUENCY SELECT** knob again and the cursor should now be underscoring the channel number. Select the desired memory location to insert the frequency. NOTE that memory 25 should be us~d for an emergency frequency as this is accessed by the priority switch.
- e. Press the **FREQUENCY FLIP/FLOP** for 1 second and the word STORE should appear indicating that it has been stored into memory.
- f. Repeat the above for other memory channels. Up to 25 channels can be programmed. Only programmed channels will be displayed.

- g. To delete a channel, select the channel number to delete, hold down the **PRIORITY** switch and the word **CLEAR** will be displayed indicating that the channel has been removed.

NOTE

The channel numbers will remain displayed until you exit the programming mode, remember to select a programmed channel before exiting.

- h. To verify press the **MODE** switch to cycle through flip/flop to the **MEM** display and rotate the **FREQUENCY SELECT** knob to see the remaining memory channels.

4.3 Operation of intercom

Operation of the intercom is simple. The intercom uses the radio sidetone facility. Closing the intercom switch simply enables radio's transmit sidetone without actually keying the transmitter.

NOTE

If you elect to use a toggle switch to activate the hot-mike intercom, you may transmit with the intercom select switch ON.

5.0 Post Installation Field Adjustments:

Although the radio has been fully tested and set at the factory adjustment of the sidetone volume and microphone gain may be required to set the correct levels for your combination of equipment and aircraft. In a noisy environment reducing the microphone gain may also be required. Only make very small adjustments to these settings. Do not adjust any other setting as this will void the warranty! A "wind sock" over the mike will also help reduce wind noise in an open cockpit aircraft. If you are not comfortable with "tweaking" adjustments on the radio, you should seek assistance of an avionics shop technician with access to test equipment to insure optimum performance of the transceiver.

MICROAIR 760
VHF COMM XCVR

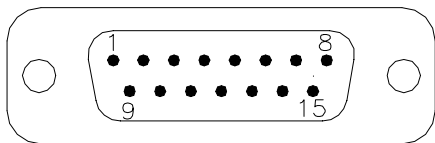

WIRE SIDE VIEW OF HARNESS (FEMALE) CONNECTOR
THIS IS HOW THE PIN LOCATIONS ARE NUMBERED
WHILE SOLDERING OR INSERTING CRIMPED PINS INTO
THE CONNECTOR HOUSING.

BACKLIGHT (40mA)
+14V (85mA/1.5A)
+14V (85mA/1.5A)

GROUND
GROUND

INTERCOM

PHONES HI

COPILOT MIC HI
PUSH TO TALK
PILOT MIC HI
MIC LO

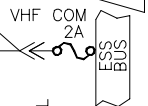

PRESS FOR INTERCOM

PRESS FOR INTERCOM



FOR STEREO AUDIO OPTION WITH
ISOLATION AMPLIFIER SEE P.2.3/2.4

PILOT PHONES
STICK MOUNTED
PTT BUTTON
(OPTIONAL)



STICK MOUNTED
PTT BUTTON
(OPTIONAL)



TITLE	PAGE
MICROAIR 760 VHF COMM	2.1

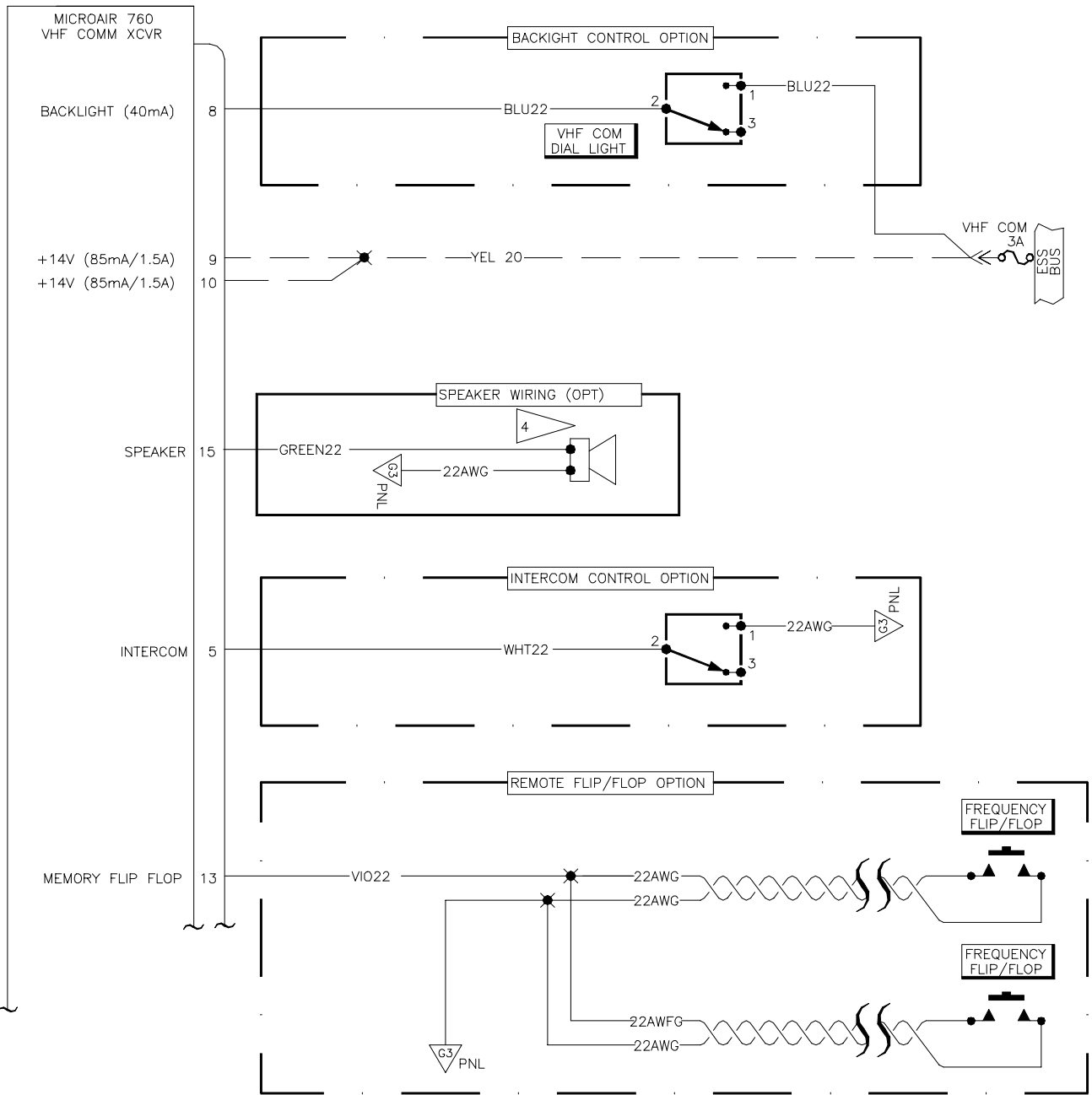

NOTES:

- 1 INSULATE ALL JACKS FROM AIRFRAME GROUND WITH EXTRUDED WASHERS OR OTHER NON-CONDUCTIVE MOUNTING MATERIAL.
- 2 FOR SINGLE SEAT AIRPLANES: IGNORE WIRING TO COPILOT JACKS AND SWITCHES. TIE OFF UNUSED RED WIRE IN MICROPHONE CABLE.
- 3 THE MICROAIR 760 DRAWS ONLY 1.5 AMPS MAXIMUM. ANY BREAKER OR FUSE FROM 2 TO 5 AMPS MAY BE USED TO PROTECT THE RADIO'S POWER WIRING HOWEVER A 2A DEVICE IS RECOMMENDED.
- 4 SPEAKER SHOULD BE 4 OHM IMPEDANCE AND HAVE THE LARGEST MAGNET YOU CAN FIND FOR THE SIZE SPEAKER YOU SELECT.
- 5 ALL WIRES IN HARNESS SUPPLIED ARE LONG ENOUGH TO ACCOMODATE A TWO PLACE, TANDEM COCKPIT AIRCRAFT. WIRES SHOULD BE TRIMED TO LENGTH TO WIRE PILOT'S JACKS AND CONTROLS FIRST. USE EXCESS WIRE TO EXTEND TO COPILOT'S JACKS AND CONTROLS. THE HARNESS CONTAINS TWO SHIELDED CABLES. THE SINGLE CONDUCTOR CABLE IS FOR HEADSETS, THE THREE-CONDUCTOR CABLE IS FOR MICROPHONES. ALL OTHER WIRING IS SINGLE, COLOR CODED CONDUCTORS AS CALLED OUT IN THIS DIAGRAM.
6. WIRES SHOWN AS ARE TWISTED PAIRS. YOU CAN USE A DRILL MOTOR TO SPIN ABOUT 2 TURNS PER INCH OF TWIST IN A PAIR OF WIRES. THE TWISTING KEEPS THE TWO WIRES TOGETHER FOR ROUTING AND REDUCES POSSIBILITY OF NOISE PICKUP. THERE ARE NO POLARITY SENSITIVE DEVICES WIRED WITH TWISTED PAIR ON THIS DIAGRAM MEANING THAT IT DOESN'T MATTER HOW THE TWO WIRES ARE CONNECTED AT EITHER END.

REV -C- 05-20-01

TITLE	PAGE
MICROAIR 760 VHF COMM	2.2

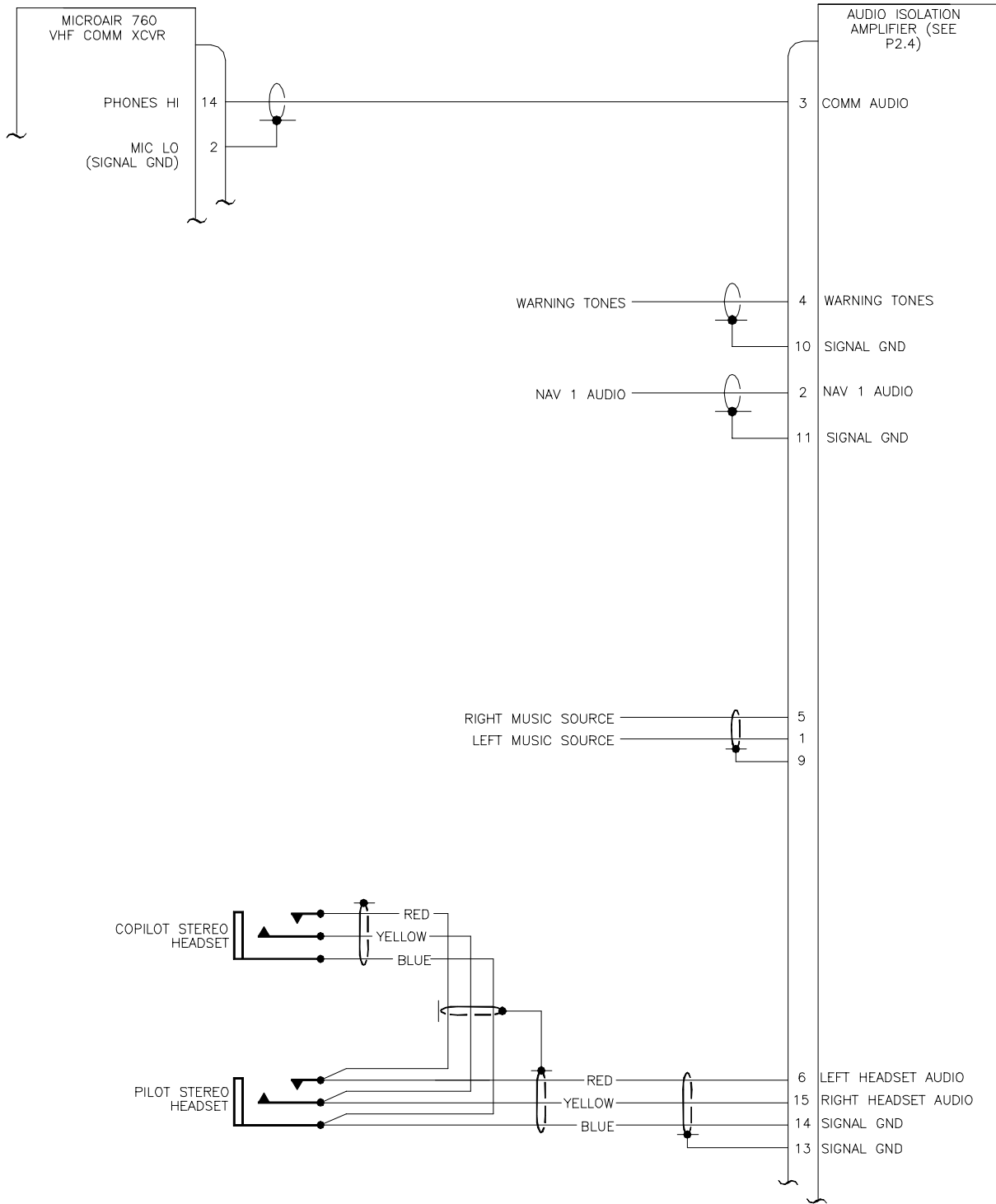

REV -C- 05-20-01

TITLE	PAGE
TYPICAL STEREO AUDIO	2.3

THIS ISOLATION AMPLIFIER IS A MODERN INCARNATION OF AMPLIFIERS USED ON LIGHT AIRCRAFT OF YESTERYEAR EXCEPT THAT (1) IT DOES NOT HAVE A SPEAKER AMPLIFIER (WE'VE LEARNED TO VALUE OUR HEARING OVER THE YEARS) AND (2) IT SUPPORTS STEREO HEADSETS FOR MUSIC WHILE MIXING THE MONAURAL AVIATION SIGNALS TOGETHER SO THEY'RE HEARD IN BOTH EARS.

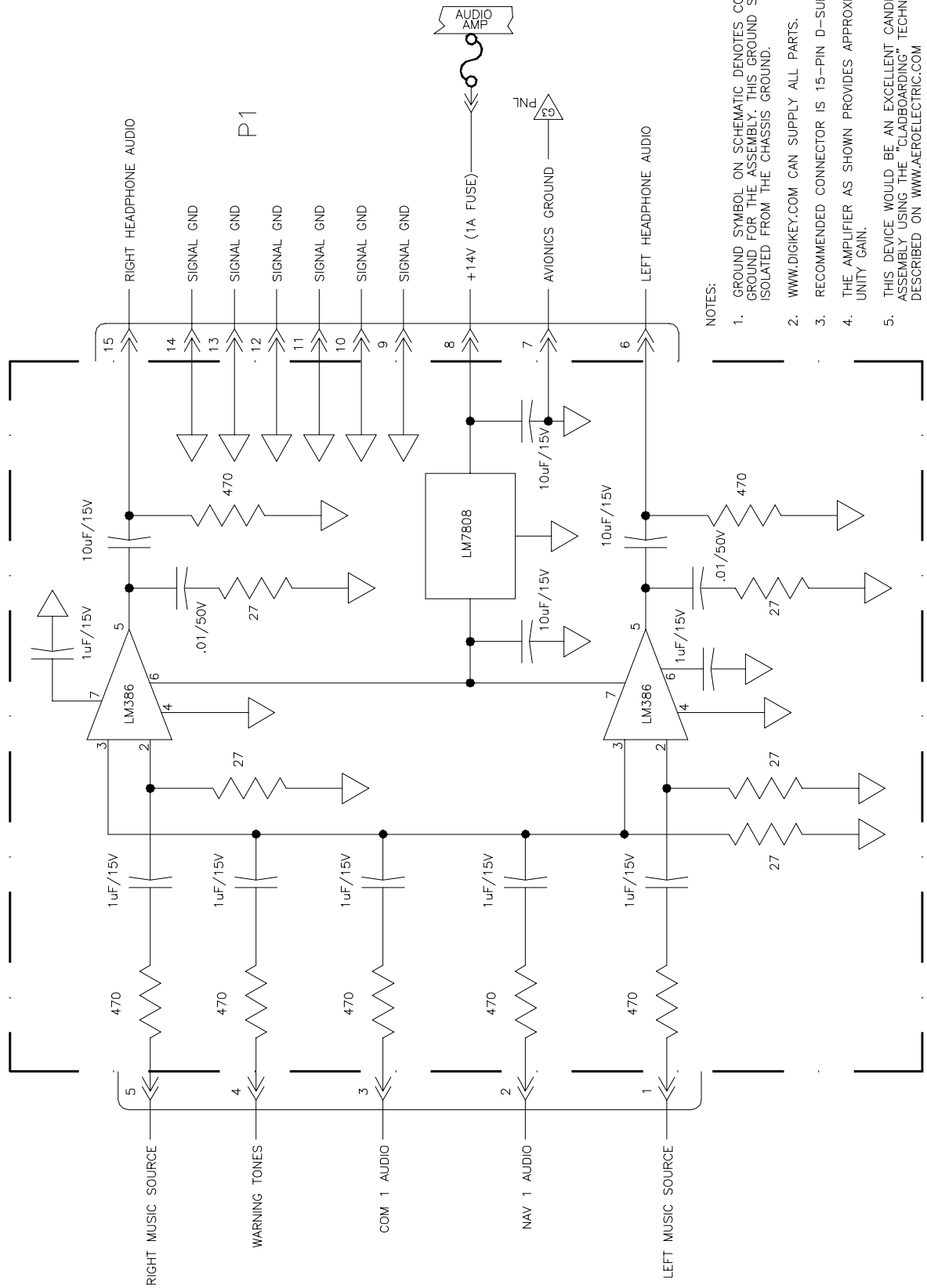

NOTES:

1. GROUND SYMBOL ON SCHEMATIC DENOTES COMMON GROUND FOR THE ASSEMBLY. THIS GROUND SHOULD ISOLATED FROM THE CHASSIS GROUND.
2. WWW.DIGIKEY.COM CAN SUPPLY ALL PARTS.
3. RECOMMENDED CONNECTOR IS 15-PIN D-SUB.
4. THE AMPLIFIER AS SHOWN PROVIDES APPROXIMATELY UNITY GAIN.
5. THIS DEVICE WOULD BE AN EXCELLENT CANDIDATE FOR ASSEMBLY USING THE "CLADBOARDING" TECHNIQUE DESCRIBED ON WWW.AEROELECTRIC.COM

TITLE	PAGE
AUDIO ISOLATION AMPLIFIER	2.4

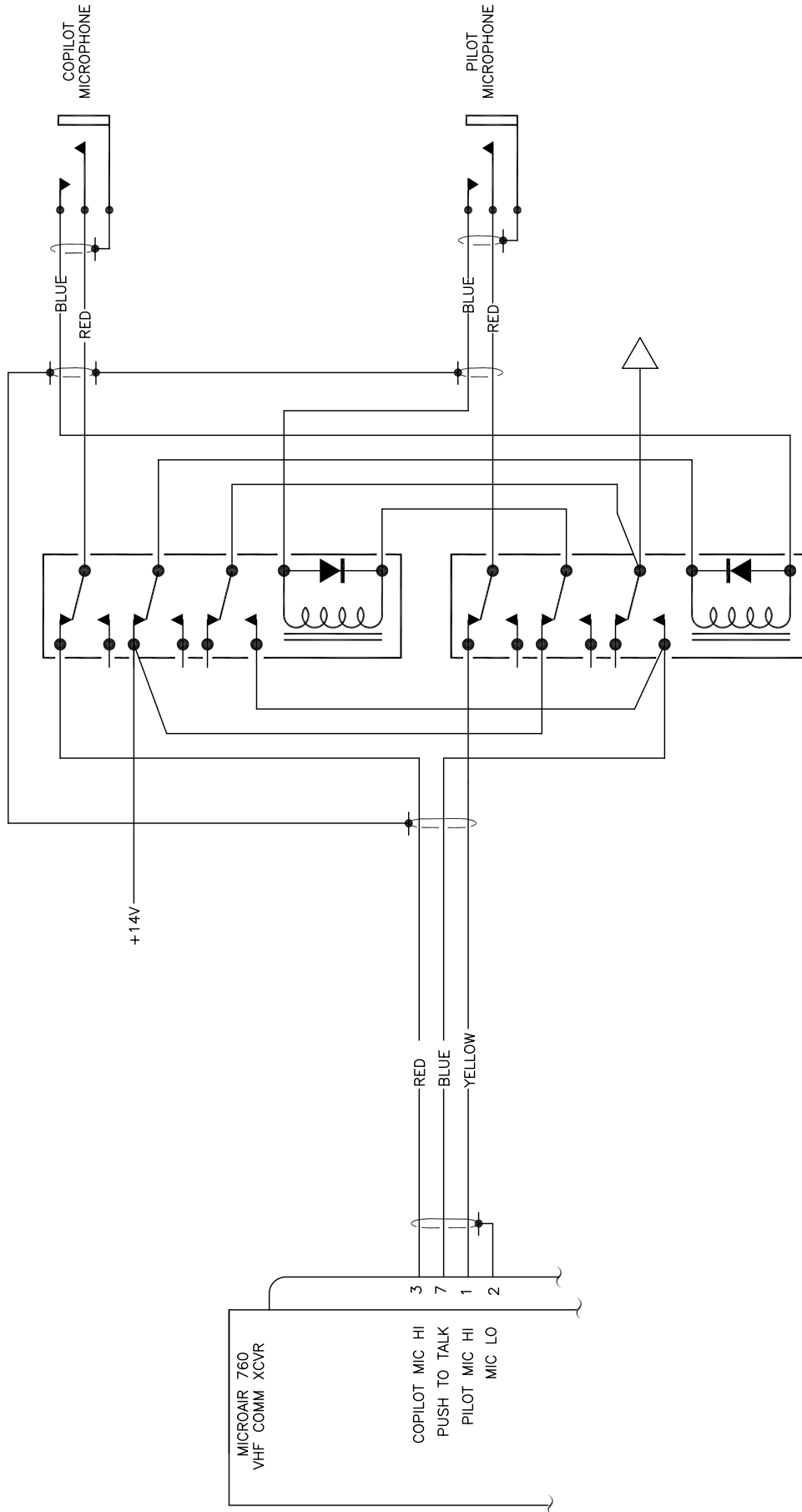

1. THIS CIRCUIT PROVIDES FIRST-COME/FIRST-SERVE ACCESS TO THE TRANSMITTER BY EITHER PILOT WITH LOCKOUT AND MUTING OF OTHER PILOT'S MICROPHONE.
2. SUGGESTED RELAYS: POTTER BRUMFIELD KHA 4PDT MINATURE (DIGKEY CAT# PB142)
3. MOUNTING OPTIONS: YOU MAY SOLDER DIRECTLY TO RELAY TERMINALS -OR- INSTALL RELAYS IN SOCKETS (DIGKEY CAT# PB144) HELD IN PLACE WITH SPRING WIRE BALL (DIGKEY CAT# PB146).
5. DIODES 1N4001 OR SIMILAR
6. ALL WIRING 22AWG.

REV -A- 10-06-03

TITLE	PAGE
FIRST-COME/FIRST-SERVED PTT AND MIC LOCKOUT	2.5